

SG 4970

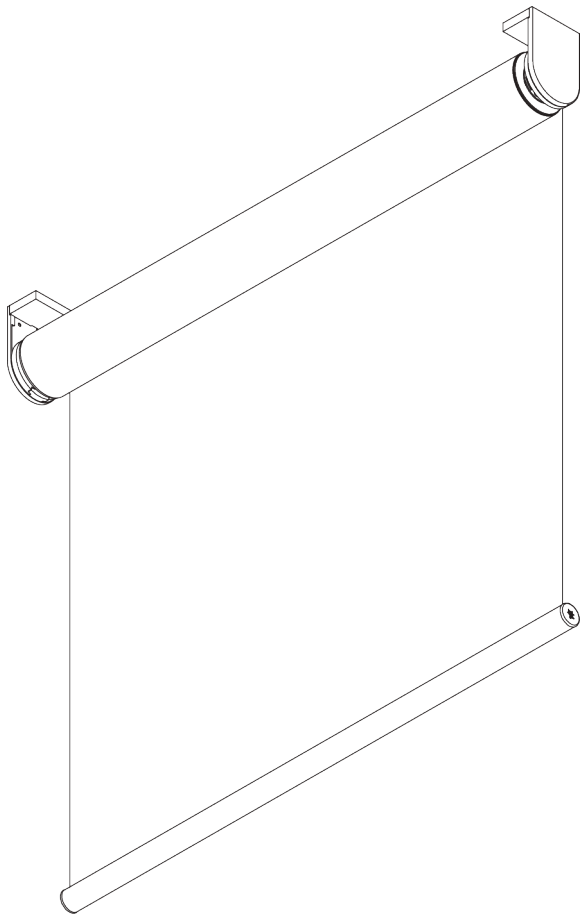
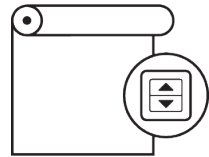

INFORMATION PRODUIT

- **Mode de commande:** Motorisé
- **Gamme:** M - L
- **Installation:** Plafond, Murale, Encastré
- **Couleurs:** Blanc RAL 9016, Gris RAL 7035, Noir RAL 9005
- **Tissus:** Se référer à la collection tissu Silent Gliss

Caractéristiques:

- Moteur silencieux et rapide, fin de courses lente
- Plusieurs options de commandes
- Système double possible
- Support click
- Fascia, boîtier, profil de montage

04/2024/V3

SPÉCIFICATION SYSTÈME

A. DIMENSIONS SYSTÈME

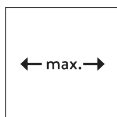

Système individuel: 3.4 m
Système double: 6.8 m

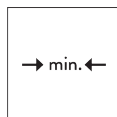

*65 cm**
**voir la table des*
spécifications moteurs

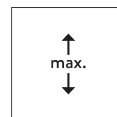

5 m

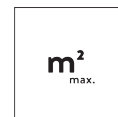

Système individuel: 17 m²
Système double: 34 m²



10 kg

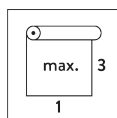

Rapport largeur / hauteur
recommandé
max. 1:3

B. PROFIL

Information profil

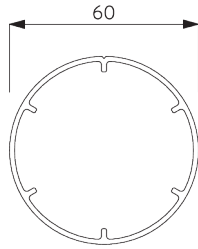

SG 11037

Profil ø 60 mm



SG 10760

Barre de lestage

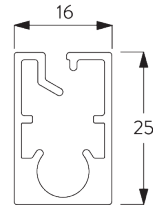

SG 10770

Barre de lestage

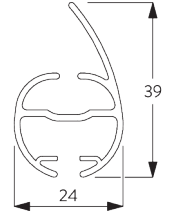

SG 4903

Barre de lestage

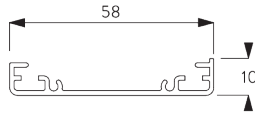

SG 11181

Profil de montage



SG 11530

Profil de montage 110 mm

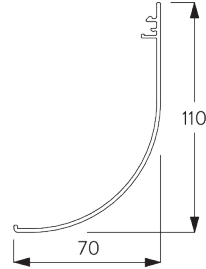

SG 11531

Fascia rond 110 mm

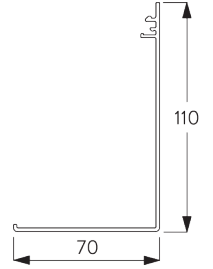

SG 11532

Fascia carré 110 mm

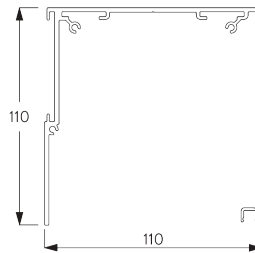

SG 11533

Boîtier 110 mm

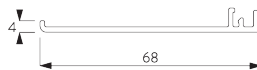

SG 11534

Boîtier cache 110 mm

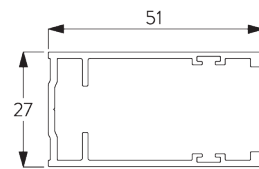

SG 11542

Profil de guidage

C. PRISE DE MESURE

y compris cache support

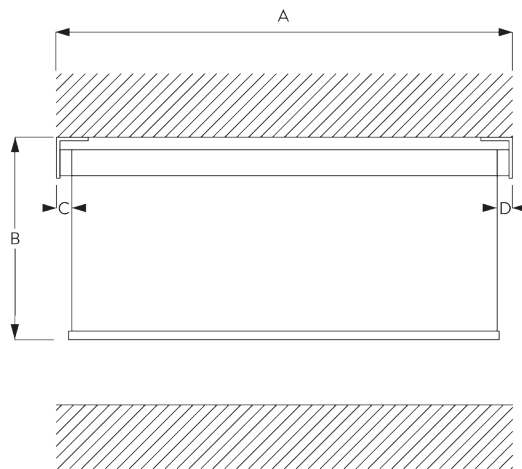

A: Largeur du système

B: Hauteur du système

C: Passage lumière 18 mm

D: Passage lumière côté manoeuvre : 25 mm

Note:

Passage de lumière variable, voir spécifications moteurs.
Toutes les dimensions comprennent 2 mm pour les caches supports par côté!

Fascia / Boîtier

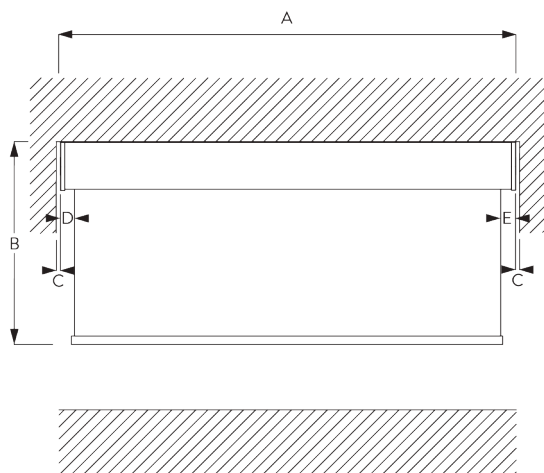

- A: Largeur du système
- B: Hauteur du système
- C: Écart: min. 10 mm (lorsque le cache support est utilisé)*
- D: Passage lumière 20 mm
- E: Passage lumière côté manoeuvre : 27 mm

Note:
Passage de lumière variable, voir spécifications moteurs.
*Possibilité de rendre le fascia plus large que le système pour réduire l'écart entre le mur et le système.

Fascia / boîtier avec profilés de guidage SG 11542

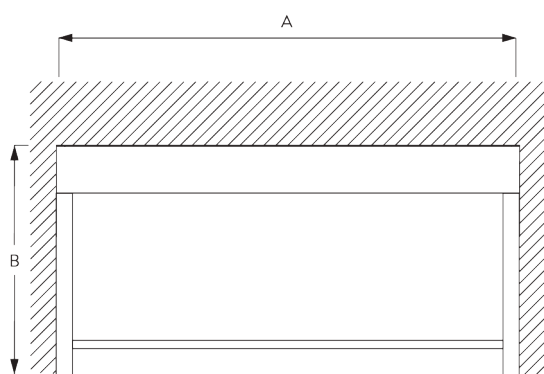

- A: Largeur du système
- B: Hauteur du système

INSTALLATION

A. INSTRUCTION DE POSE

Pour des informations détaillées, se référer au site web Silent Gliss.

Points de fixation



Supports (mural / plafond)

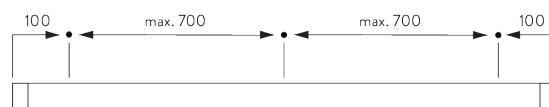

Fascia / boîtier & profil de montage SG 11181 (mural / plafond)

B. FIXATION
PLAFOND

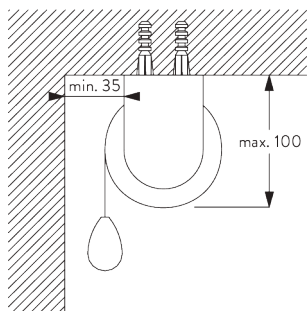

Supports

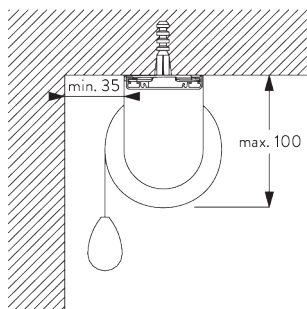

Profil de montage SG 11181 et bride SG 11180

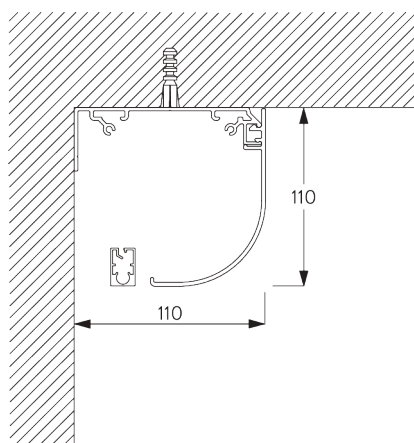

Fascia rond

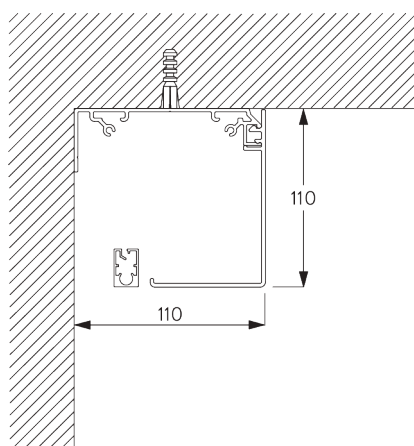

Fascia carré

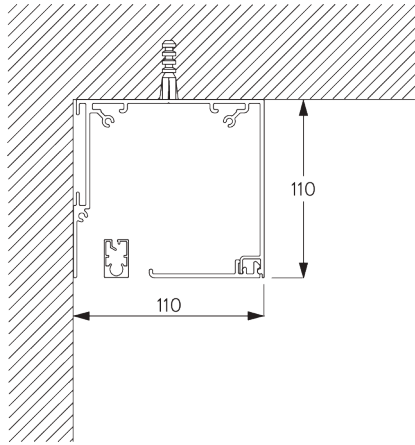

Boîtier

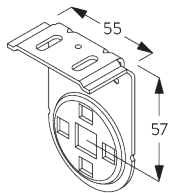

SG 11172
Support

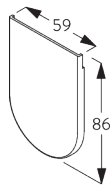

SG 11173
Cache support

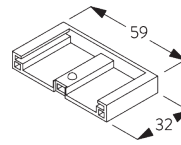

SG 11174
Cache pour vis

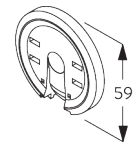

SG 11175
Support click

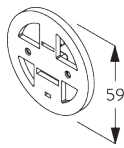

SG 11177
Support moteur

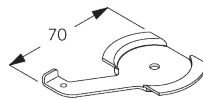

SG 11180
Bride

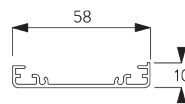

SG 11181
Profil de montage

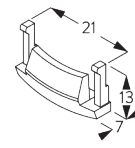

SG 11179
Cache

C. FIXATION MURALE

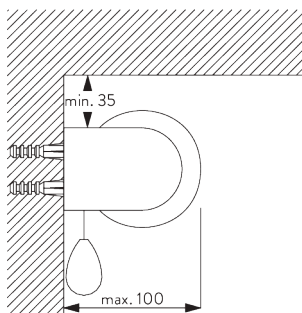

Supports

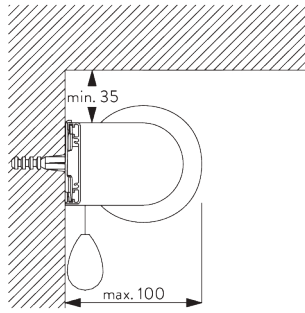

Profil de montage SG 11181 et bride SG 11180

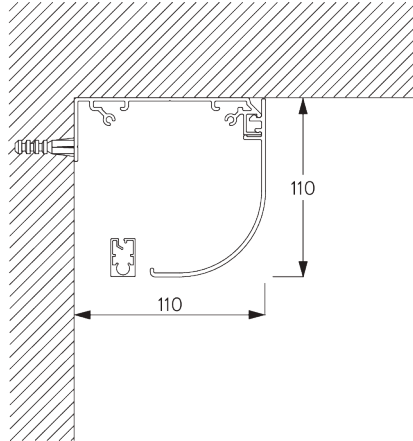

Fascia rond

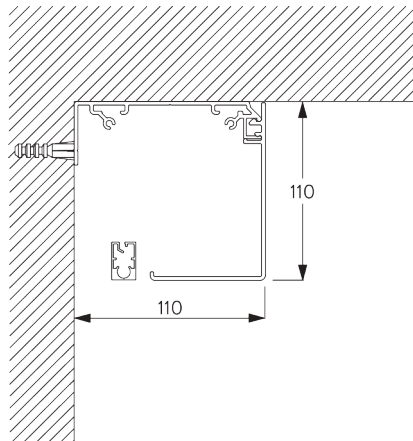

Fascia carré

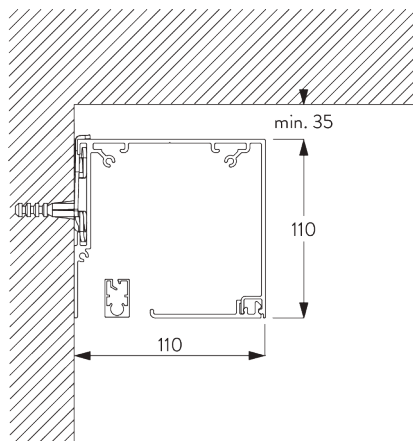

Boîtier avec bride SG 11180

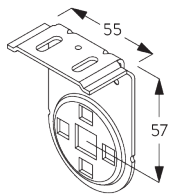

SG 11172
Support

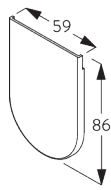

SG 11173
Cache support

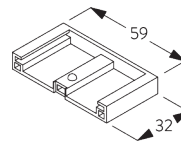

SG 11174
Cache pour vis

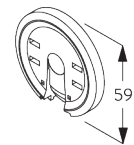

SG 11175
Support click

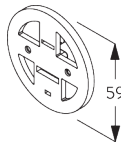

SG 11177
Support moteur

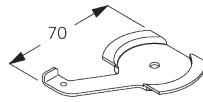

SG 11180
Bride

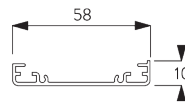

SG 11181
Profil de montage

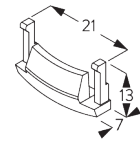

SG 11179
Cache

D. FIXATION ENCASTRÉE

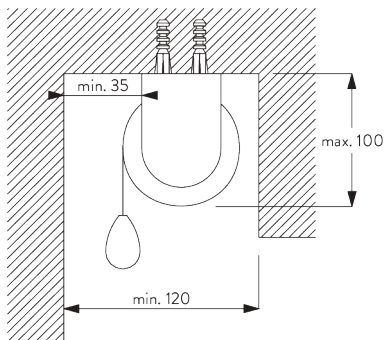

Supports

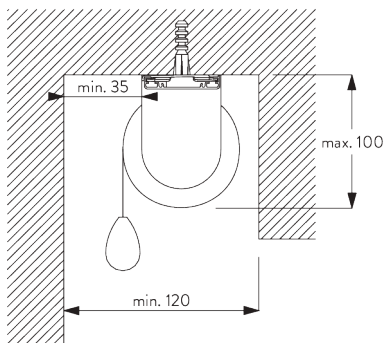

Profil de montage SG 11181 et bride SG 11180

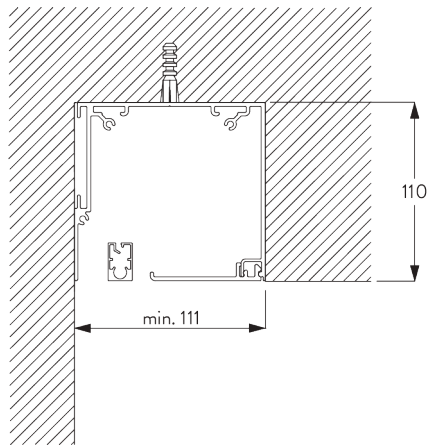

Boîtier

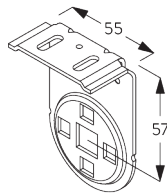

SG 11172
Support

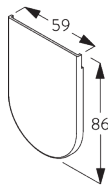

SG 11173
Cache support

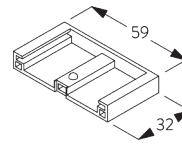

SG 11174
Cache pour vis

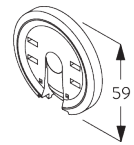

SG 11175
Support click

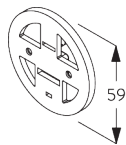

SG 11177
Support moteur

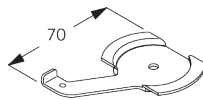

SG 11180
Bride

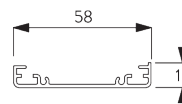

SG 11181
Profil de montage

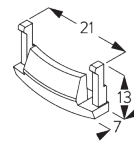

SG 11179
Cache

**E. FIXATION AVEC
OPTION DE
GUIDAGE**

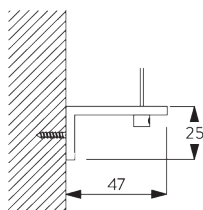

SG 3036
Equerre 47 mm

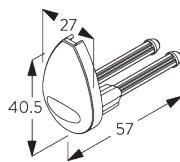

SG 4944
Embout pour barre de lestage
(guidage)

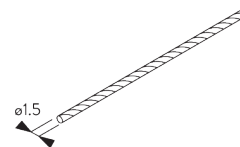

SG 4948
Câble de guidage ø 1.5 mm

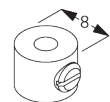

SG 8249
Serre câble

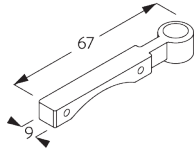

SG 11182

Guide latéral du support de fil

OPTIONS SYSTÈME

A. DÉROULEMENT DE LA TOILE

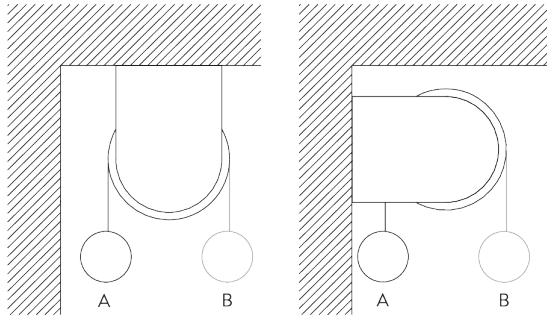

A: Déroulement au plus près de la fenêtre (standard)

B: Déroulement vers l'intérieur de la pièce (option)

B. PROFIL DE MONTAGE

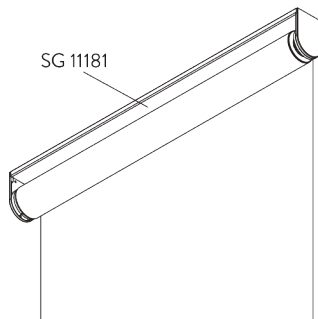

C. GUIDAGE

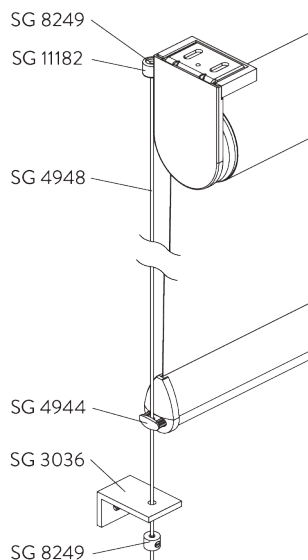

Accessoires complémentaires :

- 2x SG 3036 Support
- 2x SG 4944 Embout pour barre de lestage (guidage)
- 2x SG 4948 Câble de guidage \varnothing 1.5 mm
- 4x SG 8249 Serre câble
- 2x SG 11182 Pièce d'accroche câble haute

Note:

- Le passage de lumière latéral augmente avec l'option de guidage
- Guidage sur pente maxi de 15°
- Utilisable uniquement avec la barre de lestage SG 4903

D. SYSTÈME DOUBLE CONNECTÉ

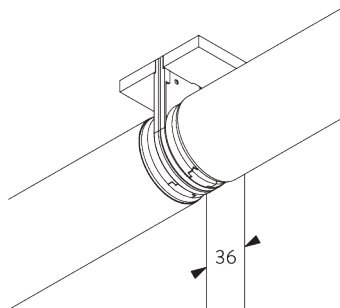

Accessoires complémentaires :

- 1x SG 11175 Support click
- 1x SG 11183 Ecrou de connection
- 2x SG 11184 Cache support intermédiaire
- 1x SG 11195 Adapateur de connection du tube

E. FASCIA / BOÎTIER

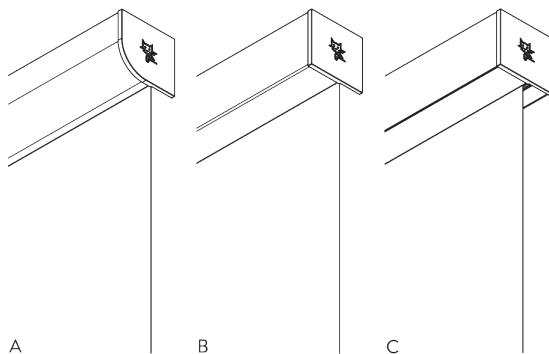

A: Fascia rond
B: Fascia carré
C: Boîtier

Taille:

- 110 x 110 mm

Note:

- Utilisable uniquement avec la barre de lestage SG 10770
- Impossible avec les systèmes connectés
- Deux systèmes avec un fascia possible sur demande

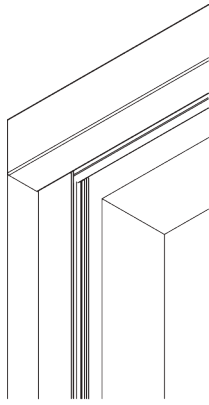

Profil de guidage SG 11542 en option à utiliser avec Fascia ou Boîtier.

Note:

- Uniquement pour installation dans des cadres de fenêtres
- Box: seulement encastré

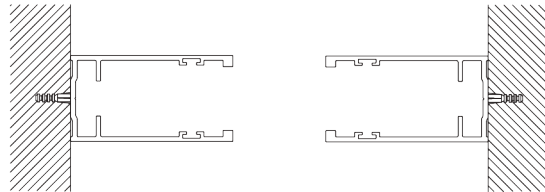

MOTEURS ET CONTRÔLES

A. CARACTÉRISTIQUES MOTEURS

Moteurs	Série 50	Série 20	Série 20	Série 10 K	Série 5
	SG 11251	SG 10523	SG 10522	SG 10514	SG 10715

Caractéristiques moteurs

Fin de course souple	•	•	•		
Fin de course électronique	•	•	•		
Compteur électronique de révolution moteurs (illimité)	•	•	•		
Fin de course mécanique				•	•
Compteur mécanique de révolution moteurs (limité)				•	•
Deux fins de course intermédiaires possibles		•			
Barre de lestage alignement	•				
Arrêt moteur silencieux		•	•	•	
Branchement en parallèle possible sans relais		•	•		
Fiche de raccord moteur démontable	•	•	•		
Classe IP	IP 30	IP 44	IP 44	IP 44	IP 44

Caractéristiques de contrôle

Contrôle moteur via l'alimentation principale		•	•	•	•
SG Control L (récepteur radio intégré)		•			
Smart by Silent Gliss	•				
Compatible avec les systèmes automatés classiques (avec l'interface adéquate)		•	•	•	•

B. SPÉCIFICATIONS

MOTEURS

Voir le site Web pour le schéma de câblage.

Moteurs	Passage lumière* C / D = coté manoeuvre	Largeur mini système	Voltage	Ampérage	Fréquence	Vitesse	Fréquence récepteur
Série 50 (Smart by Silent Gliss)							
SG 11251	C: 18 mm / D: 26 mm	65 cm	24 V DC	1.5 A	n/a	32 rpm	n/a
Série 20							
SG 10522 (Standard)	C: 18 mm / D: 25 mm	65 cm	230 V AC	0.55 A	50 Hz	30 rpm	-
SG 10523	C: 18 mm / D: 25 mm	65 cm	230 V AC	0.55 A	50 Hz	30 rpm	868/915 MHz
Série 10 K							
SG 10514	C: 18 mm / D: 25 mm	53 cm	230 V AC	0.52 A	50 Hz	30 rpm	-
Série 5							
SG 10715	C: 18 mm / D: 25 mm	65 cm	230 V AC	0.485 A	50-60 Hz	28 rpm	-

*Passage lumière Fascia ou boîtier: C +3 mm / D +2 mm (Série 20: C +2 mm / D +2 mm)

C. MODE DE COMMANDE

Voir le catalogue "Contrôles" pour des détails.

Inverseur mural



Le système peut être commandé par un inverseur mural.

SG Control L



Plusieurs télécommandes manuelles et murales disponibles.



Application Silent Gliss Move.

Smart by Silent Gliss



Système de communication bidirectionnel de conception ouverte qui permet d'intégrer parfaitement les produits à la plupart des principaux systèmes de contrôle domestique.











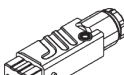

D. PLANS DE BRANCHEMENT



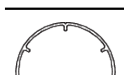

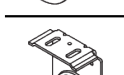

Se référer au site web Silent Gliss.











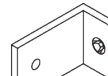



ACCESSOIRES



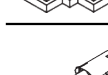







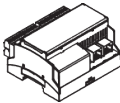

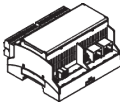
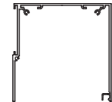

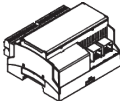

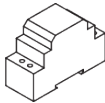

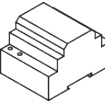

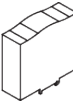





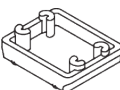

A. ACCESSOIRES STANDARDS

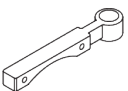
	SG 4223 Bande adhésif 14 mm
	SG 4226 Bande adhésif 30 mm
	SG 9917 Fiche raccordement male
	SG 10284 Anneau
	SG 10522 Moteur 230V AC, série 20 S 3/30
	SG 10760 Barre de lestage
	SG 10761 Embout pour barre de lestage
	SG 11037 Profil ø 60 mm
	SG 11165 Adaptateur pour profil
	SG 11172 Support
	SG 11173 Cache support
	SG 11174 Cache pour vis
	SG 11175 Support click
	SG 11176 Adaptateur de tube de moteur

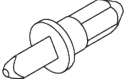
	SG 11177 Support moteur
	SG 11179 Cache
	SG 11323 Vis KA35x12
	SG 11358 Adaptateur pour moteur série 10/20

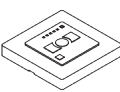
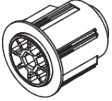
B. ACCESSOIRES EN OPTION

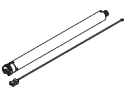
	SG 3036 Equerre 47 mm
	SG 4508 Brosse 5x7
	SG 4903 Barre de lestage
	SG 4944 Embout pour barre de lestage (guidage)
	SG 4948 Câble de guidage ø 1.5 mm
	SG 8249 Serre câble
	SG 9916 Hirschmann Kit d'accouplement
	SG 9959 Unité Contrôle Central (relais)
	SG 10293 Câble de branchement moteur - 3, 5 et 10 m en option
	SG 10300 Télécommande radio 1 canal
	SG 10302 Télécommande radio 5 canaux + 1 générale
	SG 10303 Télécommande radio 10 canaux 2 sous groupes 1 générale
	SG 10498 Vis 2.9x9.5
	SG 10514 Moteur 230V AC, série 10 S 3/30 K

	SG 10523 Moteur 230V AC, série 20 S 3/30, récepteur radio		SG 11260 Gateway Cedia		SG 11532 Fascia carré 110 mm
	SG 10668 Bande adhésif 10 mm		SG 11261 Gateway KNX		SG 11533 Boîtier 110 mm
	SG 10715 Moteur 230V AC, série 5 S 6/28		SG 11262 Module d'extension		SG 11534 Boîtier cache 110 mm
	SG 10770 Barre de lestage		SG 11263 Alimentation 24V DC, 2.5A Rail DIN		SG 11537 Cache support rond gauche 110 mm
	SG 10771 Embout pour barre de lestage		SG 11264 Alimentation 24V DC, 3.8A Rail DIN		SG 11538 Cache support rond droit 110 mm
	SG 10804 Télécommande radio 15 canaux + 5 canaux + 1 Groupé		SG 11265 Alimentation 24V DC, 5A Rail DIN		SG 11539 Cache support carré gauche 110 mm
	SG 11178 Embout pour barre de lestage		SG 11266 Alimentation 24V DC, 10A Rail DIN		SG 11540 Cache support carré droit 110 mm
	SG 11180 Bride		SG 11311 Clip pour profil de montage		SG 11542 Profil de guidage
	SG 11181 Profil de montage		SG 11359 Entraînement par moteur série 5		SG 11544 Support gauche 110 mm
	SG 11182 Guide latéral du support de fil		SG 11460 Cache pour Hirschmann prise de courant		SG 11545 Support droite 110 mm
	SG 11183 Boulon de connexion		SG 11480 Télécommande radio murale 1 canal		
	SG 11184 Cache support pour systèmes connectés		SG 11490 Télécommande radio murale 5+1 canaux		
	SG 11195 Adaptateur pour systèmes connectés		SG 11530 Profil de montage 110 mm		
	SG 11251 Moteur 24V DC, 50-Series S 3/32		SG 11531 Fascia rond 110 mm		

